

SPEED CONTROL OF PFC BASED BLDC MOTOR USING CSC CONVERTER

¹.R.Sivakami ²k. Radha ³ D. Sabina

¹ Assistant professor/EEE Dr.SJS Paul Memorial College of Engg&Tech, Puducherry.
sivakamieeee@gmail.com

^{2,3}UG Scholor/EEE Dr.SJS Paul Memorial College of Engg&Tech, Puducherry,

Abstract— This paper presents a power factor correction (PFC) based canonical switching cell (CSC) converter-fed brushless dc motor (BLDCM) drive for low-power household applications. The speed of BLDCM is controlled by varying the dc-bus voltage of voltage source inverter (VSI). The BLDCM is electronically commutated for reduced switching losses in VSI due to low-frequency switching. A front-end CSC converter operating in discontinuous inductor current mode (DICM) is used for dc-bus voltage control with unity power factor at ac mains.

Index Terms— Brushless dc motor (BLDCM), canonical switching cell (CSC) converter, discontinuous inductor current mode (DICM), power factor correction (PFC), power quality.

INTRODUCTION:

Among numerous motors, brushless dc motor (BLDCM) is preferred in many low and medium power applications including household appliances, industrial tools, heating ventilation and air conditioning (HVAC), medical equipments, and precise motion control systems. BLDCM is preferred because of its high torque/inertia ratio, high efficiency, ruggedness, and low-electro-magnetic interference (EMI) problems.

The BLDCM consists of three-phase concentrated windings and rotor has permanent magnets. It is also known as an electronically commutated motor (ECM) since an electronic commutation based on rotor position via a three-phase voltage source inverter (VSI) is used.

A conventional scheme of BLDCM drive fed by an uncontrolled rectifier and a dc-link capacitor followed by a three-phase pulse width modulation (PWM)-based VSI is used for feeding the BLDCM [10]. This type of scheme draws peaky, harmonic rich current from the supply and leads to a high value of total harmonic distortion (THD) of supply current and very low power factor at ac mains as shown in [11]. A very high THD of supply current of 65.3% and a very poor power factor of 0.72 is achieved front-end power factor correction (PFC) converter is used after the diode bridge rectifier (DBR) for improving the quality. Madani et al. [22] have proposed a boost half bridge PFC-based BLDCM drive using four switch VSI. This also requires a necessary PWM

operation of VSI and PFC half bridge boost converter, which introduces high switching losses in the overall system. These switching losses are reduced by using a concept of variable dc-link voltage for speed control of BLDC motor [24]. This utilizes the VSI to operate in low-frequency switching required for electronic commutation of BLDC motor, hence reduces the switching losses associated with it.

CANONICAL SWITCHING CELL CONVERTER:

The concept of switching cells in power electronic circuits started in the late 1970's [9]. It started with the canonical cell where an inductor, a capacitor, and a single-pole double throw switch form a basic canonical switching cell shown in Fig.1. The cell has three terminals A, B, and C and each of them can be used as an input/output/common terminal. If terminal A is used as an input, B as an output and C is used as the common terminal; the canonical circuit forms one kind of dc-dc converter. Six different combinations can be formed by changing the function of the three terminals in different combinations. Among these six combinations, only three distinct effective circuits are found, whereas the others are functionally the same. Thus, using these three combinations, the buck, boost, and buck-boost converter can be formed.

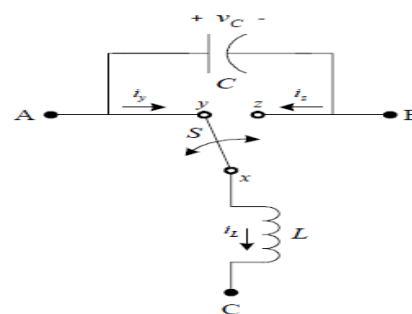

FIG.1 BASIC CIRCUIT DIAGRAM

Modes of Operation:

A CSC converter operating in Discontinuous Inductor Current Mode (DCIM), the current in inductor L_i becomes discontinuous in a switching period T_s as shown in fig.

Mode-1:

When switch S_w turned ON, the energy from the supply and stored energy in the intermediate capacitor C_1 are transferred to inductor L_i are shown in fig-2. In this process voltage across intermediate capacitor V_{C1} reduces, while inductor current i_{L_i} and dc link voltage V_{dc} are increased. The designed value of intermediate capacitor V_{C1} are large enough to hold energy such that voltage across it becomes discontinuous.

Mode-2

The switch turned OFF, the capacitor C_1 charged through supply current while inductor L_i starts discharging hence voltage V_{C1} starts increasing, while current i_{L_i} decreases in this mode.

Mode-3:

This discontinuous conduction mode of operation as inductor L_i completely discharged and current i_{L_i} becomes zero as shown in fig. the voltage across C_1 continuous to increase, while V_{dc} starts decreasing.

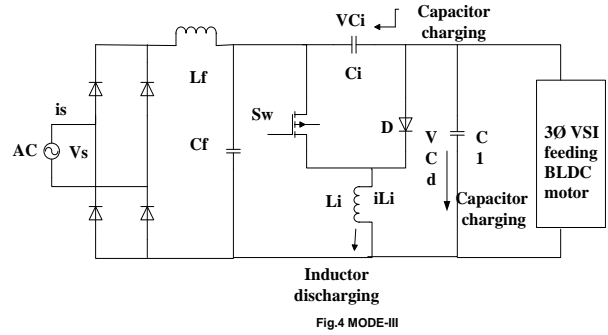
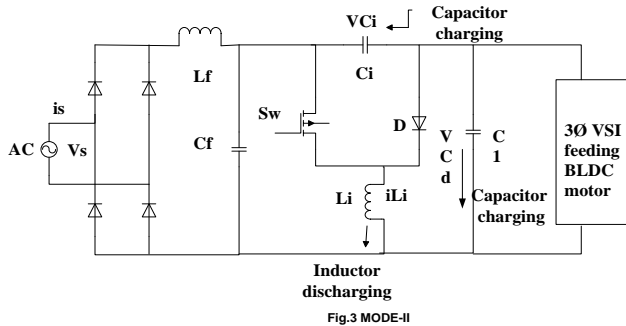
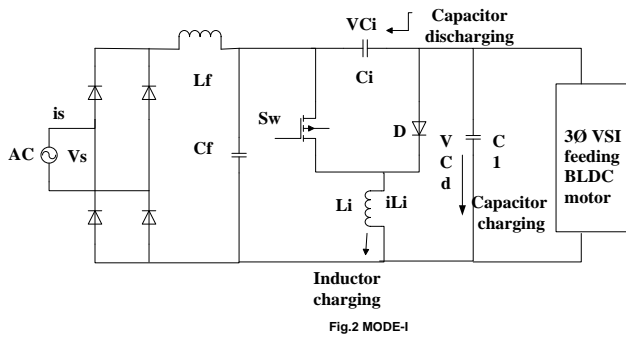

The design equations of canonical switching cell converter are given below.

For supply voltage (V_s) of 220V the voltage appearing Diode bridge rectifier (DBR) is given as,

$$V_{in} = \frac{2\sqrt{2}V_s}{\pi} = \frac{2\sqrt{2} \times 220}{\pi} = 198V$$

A nominal duty ratio (d_n) are given as,

$$d_n = \frac{V_{dcn}}{V_{dcn} + V_{in}} = \frac{120}{120 + 198} = 0.3774$$

The critical value of inductance L_{ic} are given as,

$$L_{ic} = \frac{V_{in} d_{nom}}{2 \ln fs} = \frac{198 \times 0.3774}{2 \times \left(\frac{400}{198}\right) \times 20000}$$

$$L_{ic} = 924.72\mu H$$

Now to operate in CSC converter in PFC, the value of inductor L_i taken around $1/10^{th}$ of critical value,

$$L_i < L_{ic}/10$$

An intermediate capacitor C_1 designed for permitted ripple voltage of ΔV_{C1} across it and take as 10% of V_c voltage across intermediate capacitor

i.e $(V_{in} + V_{dcnom}) = (198 + 120) = (318V)$ given as,

$$C_1 = \frac{V_{dcnom} d_{nom}}{fs R_L \Delta V_{C1}} = \frac{120 \times 0.3774}{20000 \times 36 \times 0.4 \times 318}$$

$$C_1 = 440nF$$

The dc-link capacitor (C_d) is calculated as,

$$C_d = \frac{I_d}{2\omega L \Delta V_{dc}}$$

$$= \frac{\left(\frac{400}{120}\right)}{2 \times 314 \times 0.02 \times 120}$$

$$Cd = 2200\mu F$$

To avoid the reflection of high-order harmonics in supply system, a low-pass inductive-capacitive (LC) filter is designed whose maximum, C_{max} is calculated as,

$$c_{max} = \frac{I_{peak}}{\omega L V_{peak}} \tan(\phi)$$

$$= \frac{\left(\frac{400\sqrt{2}}{220}\right)}{314 \times 220\sqrt{2}} \tan(1^\circ) \approx 459.4nF$$

$$C_f = 330nF$$

The additional value of inductance required as,

$$L_f = L_{req} + L_s \rightarrow \frac{1}{4\pi^2 f_c^2 C_f} = L_{req} + 0.04 \left(\frac{1}{\omega_L}\right) \left(\frac{V_s^2}{P}\right)$$

$$L_{req} = \frac{1}{4\pi^2 \times 2000^2 \times 330 \times 10^{-9}} - 0.04 \left(\frac{1}{314}\right) \left(\frac{200^2}{400}\right)$$

$$L_{req} = 3.77mH$$

Finally, LC filter with values of $L_f=3.77mH$ and $C_f=330nF$.

Where,

V_{dcn} - nominal voltage

f_c - Switching frequency

RL- load resistance

P- Power

ωL - line frequency

I_d - dc-link current

I_{peak} - supply current

V_{peak} - supply voltage

θ - Displacement angle

Brushless Dc Motor:

Brushless Direct Current (BLDC) motors are one of the motor types rapidly gaining popularity. BLDC motors are used in industries such as Appliances, Automotive, Aerospace, Consumer, Medical, Industrial Automation Equipment and Instrumentation.

As the name implies, BLDC motors do not brushes for commutation; instead, they are electronically commutated. BLDC motors have many advantages over brushed DC motors and induction motors. A few of these are

- Better speed Vs torque characteristics
- High dynamic response
- High efficiency
- Long operating life
- Noiseless operation
- Higher speed range

For constant operation of BLDC motor it needs a converter circuit in its front end to reduce the input losses and distortions in current. A brushless motor is constructed with a permanent magnet rotor and wire wound stator poles. Electrical energy is converted to mechanical energy by the magnetic attractive forces between the permanent magnet rotor and a rotating magnetic field induced in the wound stator poles.

Hall Sensors:

Unlike a brushed DC motor, the commutation of a BLDC motor is controlled electronically. To rotate the BLDC motor, the stator windings should be energized in a sequence. Rotor position is sensed using Hall Effect sensors embedded into the stator. Most BLDC motors have three Hall sensors embedded into the stator on the non-driving end of the motor. Whenever the rotor magnetic poles pass near the Hall sensors, they give a high or low signal, indicating the N or S pole is passing near the sensors. Based on the combination of these three Hall sensor signals, the exact sequence of commutation can be determined.

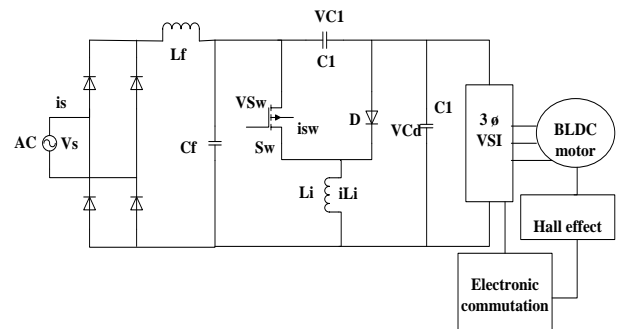

Fig.5 BLDC motor drive using CSC converter

Simulation Work:

The circuit diagram of design of canonical switching cell are given below,

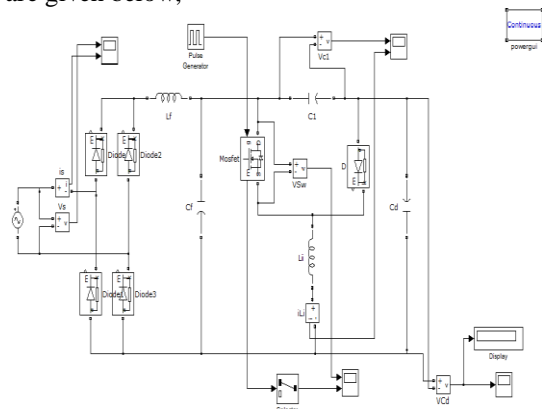

Fig.6 Canonical switching cell converter

When A.C supply is given to circuit it get converted to D.C source by using rectifiers. The input voltage and current get measured using scope. Filter is an electrical network that alters the amplitude or phase characteristics of a signal with respect to frequency. It will not add any new frequency to

input signal; but it will change the component frequency of that signal. These are always connected in parallel.

Here LC filters are used to eliminate to

- Line harmonic currents
- To improve power factor
- To reduce electrical interference.

Canonical switching cell converter consists of Mosfet switch, diode, inductor and capacitor whose are connected circularly. The Mosfet switch consists of Drain, Source, and Gate. The drain side connected to intermediate capacitor (C_1) whose value is 440nF. These capacitors are connected to diode (D). The source side and this diode are connected to inductor (Li) at ground side whose value is 70 μ H. The dc-link capacitors are connected parallelly across canonical cell converter whose value 2200 μ F is selected. The gate signal for Mosfet switch are provided by pulse generator whose switching frequency are 20000Hz , amplitude are 5 and pulse width are 38%. The output for CSC converter and Mosfet switch are given shown below.

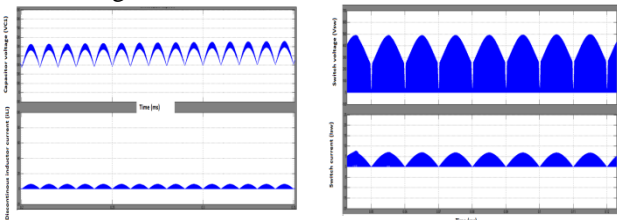

Fig.7(a) waveform of canonical switching cell converter
 (b)waveforms of Mosfet switch.

The circuit for BLDC motor consists of voltage controller, universal bridge, gates, decoder, permanent synchronous motor, scopes, speed controlled and reference speed. The controlled voltage source can be worked under A.C or D.C source which are connected across universal bridge.

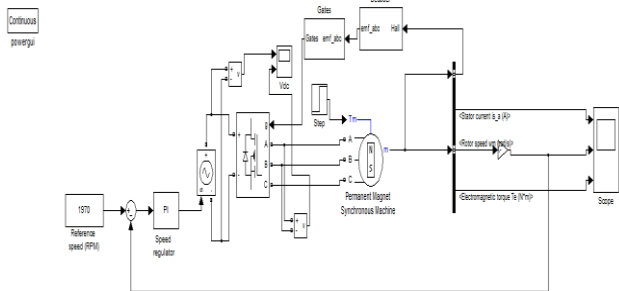

Fig.8 Closed loop operation of BLDC Motor

The supply from these source are passed through universal bridge consists of 3 line (A, B, C) and gates signals. These signals are passed through Permanent magnet synchronous machine. This block consists of 3 lines as input and torque & speed as output.

The bus selector is connected from output of Permanent magnet synchronous machine. At these selector stator current, stator speed, electromagnetic torque are measured using scope element.

The Hall Effect signal for motor are taken into bus selector and which performs decoder operation (i.e. no. of signals are

converted to one signal) and produces electromotive force signal (emf) are given in circuit and tabular column.

A speed controller is used to control DC bus voltage. The inverter gate signals are produced by decoding the hall effect signals of the motor. The motor back EMF are

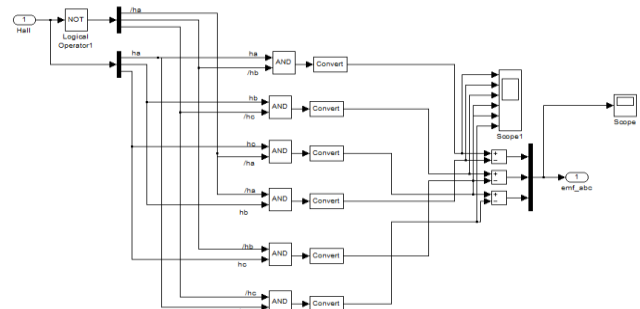

Fig.9 Decoder circuit in BLDC Motor

The input signal are splitted into two signals as NOT and AND logic operation. The NOT signal are passed through AND which converts to 6 gates signal. These signals get add together and passed through Mux (i.e. no. of input to one output). Finally emf signals are generated. The given reference speed and rotor speed are added together and passed through speed regulator. This regulator follows by PI controller and these DC signals are passed as input for controlled voltage source. From this block the universal bridge get supply and performed the operation of BLDC motor.

Gate Signal for Universal Bridge:

These emf signals are again passes through selector to produce gate pulses for universal bridge are given in table given below.

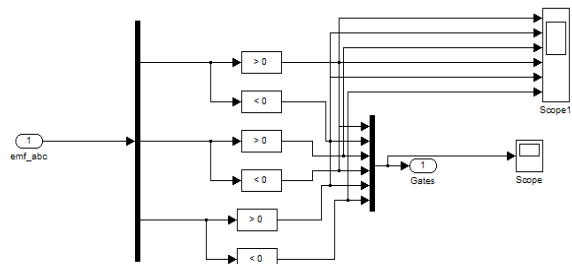

Fig.10 Gate signal for Universal Bridge

The signal emf signal are passed through selector as 3 input signal and split into 6 signals for Boolean operation. The signal which are >0 and <0 are passed through comparative block for pulse produced. These signal are passed through Demux which produces single. These signal are used as universal gate signals. The tabular column for switching states of VSI to Hall Effect rotor position signals

Emf a	Emf b	Emf c	Q1	Q2	Q3	Q4	Q5	Q6
0	0	0	0	0	0	0	0	0
0	-1	1	0	0	0	1	1	0

-1	1	0	0	1	1	0	0	0
-1	0	1	0	1	0	0	1	0
1	0	0	1	0	0	0	0	1
1	-1	-1	1	0	0	1	0	0
0	1	0	0	0	1	0	0	1
0	0	-1	0	0	0	0	0	0

Table1 conduction of switches

The simulation result for BLDC motor operation is given below.

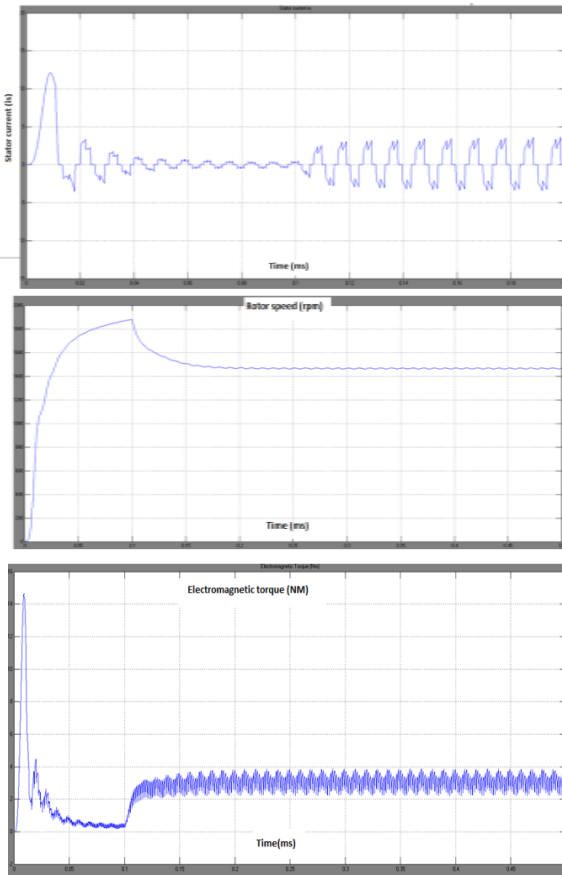

Fig.12 (a) Waveforms of stator current of BLDC Motor (b) Waveform of rotor speed of BLDC Motor (c) Waveform of torque produced in BLDC Motor

Conclusion:

A PFC based CSC converter fed BLDC motor are used to reduce switching loss. It operates in DCIM for DC link voltage control and unity power factor improves efficiency.

BLDC motor specifications

- No.of.poles=4
- Rated power (P_{rated}) =314.16W
- Dc bus voltage (V_{rated}) =200V
- Rated torque (T_{rated}) =1.5Nm
- Rated speed (N_{rated}) =2000rpm
- Torque constant (K_t) =0.74Nm/A
- Per phase resistance (R_{ph}) =14.56Ω

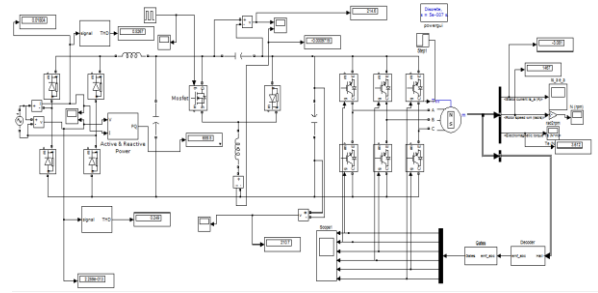

Fig.11 Circuit Diagram of BLDC Motor

Per phase inductance (L_{ph}) = 25.71 mH
 Moment of inertia= 1.3e-4Nm/s
 $K_p=0.4$
 $K_i=0.001$

REFERENCES

- [1] C. L. Xia Permanent Magnet Brushless DC Motor Drives and Controls. Hoboken, NJ, USA: Wiley, 2012.
- [2] T. Kenjo and S. Nagamori, Permanent Magnet Brushless DC Motors. Oxford, U.K.: Clarendon, 1985.
- [3] T. F. Chan, L.-T. Yan, and S.-Y. Fang, "In-wheel permanent-magnet brushless DC motor drive for an electric bicycle," IEEE Trans. Energy Convers., vol. 17, no. 2, pp. 229–233, Jun. 2002.
- [4] T. K. A. Brekken, H.M. Hapke, C. Stillinger, and J. Prudell, "Machines and drives comparison for low-power renewable energy and oscillating applications," IEEE Trans. Energy Convers. vol.25, no.4 pp.1162–1170, Dec.2010.
- [5] T. J. Sokira and W. Jaffe, Brushless DC Motors: Electronic Commutation and Control. Blue Ridge Summit, PA, USA: TAB Books, 1989.
- [6] S. Singh and B. Singh, "A voltage-controlled PFC CUK converter based PMBLDCM drive for air-conditioners," IEEE Trans. Ind. Appl., vol. 48, no. 2, pp. 832–838, Mar./Apr. 2012.
- [7] N. Mohan, T. M. Undeland, and W. P. Robbins, Power Electronics: Converters, Applications and Design. Hoboken, NJ, USA: Wiley, 2003.
- [8] B. Singh, B. N. Singh, A. Chandra, K. Al-Haddad, A. Pandey, and D.P. Kothari, "A review of single-phase improved power quality ac–dc converters," IEEE Trans. Ind. Electron., vol.50, no. 5, pp.962–981, Oct.2003.
- [9] B. Singh, S. Singh, A. Chandra, and K. Al-Haddad, "Comprehensive study of single-phase ac–dc power factor corrected converters with high frequency isolation," IEEE Trans. Ind. Informat., vol. 7, no. 4, pp. 540–556, Nov. 2011.
- [10] B. Singh and S. Singh, "Single-phase power factor controller topologies for permanent magnet brushless dc motor drives," IET Power Electron., vol. 3, no. 2, pp. 147–175, Mar. 2010.
- [11] S. B. Ozturk, O. Yang, and H. A. Toliyat, "Power factor correction of direct torque controlled brushless dc motor drive," in Proc. 42nd IAS Annu. Meet. Ind. Appl. Conf., New Orleans, LA, USA, 2007, pp. 297–304.
- [12] T. Y. Ho, M. S. Chen, L. H. Yang, and W. L. Lin, "The design of a high power factor brushless DC motor drive," in Proc. 2012 Int. Symp. Comput. Consum. Control., Taiwan, Jun. 4–6, 2012, pp. 345–348.
- [13] L. Cheng, "DSP-based variable speed motor drive with power factor correction and current harmonics compensation," in Proc. 35th IECEC, vol. 2, Las Vegas, NV, USA, Jul. 2000, pp. 1394–1399.
- [14] B. K. Lee, B. Fahimi, and M. Ehsani, "Overview of reduced parts converter topologies for AC motor drives," in Proc. 32nd Annu. IEEE Power Electron. Spec. Conf. (PESC), vol. 4, Vancouver, BC, Canada, 2001, pp. 2019–2024.
- [15] A. Barkley, D. Michaud, E. Santi, A. Monti, and D. Patterson, "Single stage brushless dc motor drive with high input power factor for single phase applications," in Proc. 37th IEEE Power Electron. Spec. Conf., Jeju Province, South Korea, 2006,