

# Design and Simulation of Four Wheel Steering System for LMV

K. Ruban<sup>#1</sup>, V. Sathishkumar<sup>#2</sup>, R. Shanmugavelan<sup>#3</sup>, S. Srinath<sup>#4</sup> and R. Ramesh<sup>\*5</sup>

<sup>#</sup> B. E Mechanical Engineering, Final year, Er. Perumal Manimekalai College of Engineering, TN, India

<sup>\*</sup> Assistant Professor, Dept. Of Mechanical Engineering, Er. Perumal Manimekalai College of Engineering, TN, India

**Abstract—** 4 Wheel Steering System is implemented in vehicles to achieve better performance at high speeds, reducing the turning radius of the car and to reduce the driver's steering effort. In most active 4 wheel steering system, the guiding computer or electronic equipment play a major role. In our project we have tried to keep the mechanism as mechanical (Hydraulic) which can be easy to manufacturing and maintenance at low cost compared to the existing electronic systems.

This project focuses on a mechanically feasible & innovative design involving a double acting hydraulic cylinder system. The movement of the rear wheels is done by the actuation of the second hydraulic cylinder. The second hydraulic cylinder is actuated through the first cylinder according to the movement of front wheel steering system.

**Index Terms—**4 wheel steering system, hydraulic cylinder system, lmv

## I. INTRODUCTION

### A. FOUR WHEEL STEERING

Nowadays there is a need of active steering systems for larger wheel base cars which needs to turn the rear wheels for directional stability and cornering at low speed easily.

#### 1) CRAB STEERING

Crab steer is the active four wheel steering which operates all the four wheels in same direction at same angle. This crab steer is mainly used to move the vehicle in straight line but with a certain angle. This crab steer is very much useful while parking the vehicle.

#### 2) PASSIVE REAR WHEEL STEERING

In four wheel steering vehicle, some of the vehicles are implemented with passive rear wheel steering system. This system turns the rear wheel slightly to the angle of front wheels to provide better stability than the crab steer at high speeds.

#### 3) IN-PHASE AND COUNTER-PHASE STEERING

The four wheel steering system performs two distinct operations. They are in-phase steering and counter phase steering. In in-phase steering the rear wheels are turned in the same direction as front wheel. In counter phase steering the

rear wheels are turned in the opposite direction of the front wheel movement.

## II. LITERATURE REVIEW

### A. STEERING

Steering is the combination of components, Linkages etc. which allows vehicle to follow the desired path. An exception is the case of railway transport by which rail tracks combined together provides the steering function. The major purpose of the steering system is to allow the driver to guide the vehicle in the exact path they need.

#### 1) RACK AND PINION, RECIRCULATING HAIL, WORM AND SECTOR

Many cars use rack and pinion steering mechanism, where the steering wheel turns the pinion gear, the pinion attached with the steering rod moves the rack, which is a linear gear that mesh with the pinion. This mechanism will convert rotary motion into linear motion. This motion applies steering torque to the swivel pin ball joints are replacing the previously used kingpins of the stub axle of the steered wheels via tie rods and a short lever arm called the steering arm. The rack and pinion mechanism has the advantage of a large feedback and direct steering feel. The disadvantage of this rack and pinion steering mechanism is not adjustable in the case of wear. So that when it was wear and developed lash in the rack and pinion mechanism, the only way is replacement.

#### 2) POWER STEERING

Power Steering helps the driver of a vehicle to steer by directing some external power to steer the wheels of the vehicle. As vehicles have become heavier and switched to front wheel drive, particularly using negative offset geometry along with increases in tire width and diameter, so the necessary effort to turn the wheels has increased, so the power steering is required to reduce the driver effort to steer the vehicle. So the vehicle manufacturers have developed power steering systems, or more correctly power-assisted steering, since on road vehicles there has to be a mechanical linkage as a fail-safe.

There are two types of power steering systems. They are hydraulic and electric/electronic power steering systems. A hybrid system is also possible which is hydraulic and electric power system. A hydraulic power steering (HPS) uses hydraulic pressure supplied by an engine-driven pump to assist the motion of turning the steering wheel. Electric power

steering (EPS) is more efficient than hydraulic power steering, since the electric power steering motor only needs electric power to provide assistance when the steering wheel is turned. In EPS the effort of assistance is easily tuneable according to the vehicle type, road speed and even driver preference. In EPS environmental hazard posed by leakage and disposal of hydraulic power steering fluid is avoided. Added to that electrical power steering assistance is not lost in case of engine fails but hydraulic power steering stops working if the engine stops. This will make the Steering double time heavier.

**3) SPEED SENSITIVE STEERING**

A recent development of power steering is speed sensitive steering because the steering is heavily assisted at low speed and lightly assisted at high speed. The manufacturers consider that the motorists might need to make large steering inputs while at the time of parking, but not while travelling at high speed. This speed-sensitive power steering systems reduce the mechanical or electrical effort when the vehicle speed increases, giving a more direct steering feel. This steering feature is gradually becoming more common in nowadays.

**4) CONDITION FOR PERFECT STEERING**

While taking a turn, the condition of perfect rolling motion will be satisfied if all the four wheel axes when projected at one point called the instantaneous centre, and when the following equation is satisfied:

$$\cot \phi - \cot \theta = c/b$$

**III. PROBLEM DEFINITION**

Nowadays all vehicles used two wheel steering system, but the performance of two wheel steering is less than four wheel steering. The vehicle with higher turning radius is facing difficulties while parking and low speed cornering. This is due to its large wheel base and wider track width of the car especially the sedans. The end users (passengers) of the vehicle prefer larger wheel base and wider track width which provides good comfort. So the manufacturer does not reduce the wheelbase and track width. In this case, the four wheel steering gives better improvement in the steering system by reducing the turning radius of the vehicle. This is mainly focusing on larger wheel base sedan's and SUV's for better steering performance and response. Hatchbacks are maintained with lower wheel base and compact in length. So we are making this project to implement in SUV's, MUV's and Sedans.

**IV. THE CONCEPT**

Our concept is to making a four wheel steering system using double acting hydraulic cylinders. In our project, we are using two double acting cylinders to achieve the rear wheel movement. The phase configuration of the four wheel steering can be changed using double acting valve (4/2 way). The hydraulic cylinder 1 is operated ie., actuated through the steering mechanism by using the links and joints. The hydraulic cylinder 2 is actuated by the fluid outlet from the

cylinder 1. The piston of the cylinder 2 is connected to the rear wheels of the vehicle.

**V. MECHANISM AND DESIGN**

The mechanisms that involves in our project are listed below:

- Steering Mechanism
- Hydraulic Mechanism
- Links and Joints

The steering mechanism may be a rack and pinion or power steering mechanism according to the manufacturer of the vehicle. We are considering rack and pinion mechanism for this design.

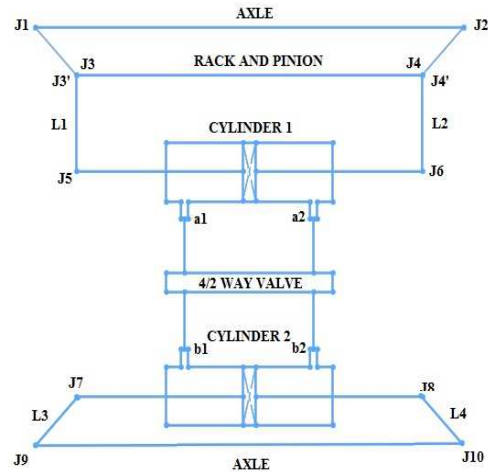

**A. HYDRAULIC MECHANISM**

The components of hydraulic mechanism are listed below:

- Double acting cylinder
- 4/2 way valve
- Hydraulic fluid
- Hoses etc.,

**1) DOUBLE ACTING CYLINDER**

Double acting cylinder is having two valves that have inlet and outlet valve which is used alternatively for obtaining reciprocating motion.

**2) 4/2 WAY VALVE**

4/2 way valve is having two types of flow configuration to change the inlet and outlet of two double acting cylinders. It will change the outlet of one cylinder to inlet of another cylinder and vice versa.

**3) HYDRAULIC FLUID**

The hydraulic fluid is compressed to its maximum capacity and then it is filled in the hydraulic cylinders at center position of piston, valves and hoses.

**4) HOSES**

Hoses are used to provide the path for the fluid flow between the two cylinders to achieve the reciprocating motion through double acting valve (4/2 way valve).

**5) HYDRAULIC MECHANISM OF OUR PROJECT**

Hydraulic cylinder 1 is connected to the 4/2 way valve by using hoses. Then the cylinder 2 is also connected to the valve. The flow configuration can be changed by the valve to achieve the in-phase and counter phase configuration.

a) *IN-PHASE CONFIGURATION*

Sequence of oil flow

a2 → b2

b1 → a1

Where a2 = c1 outlet

b2 = c2 inlet

b1 = c2 outlet

a1 = c1 inlet

The 4/2 way valve will control the flow according to the above sequence. This is the in-phase configuration of our design.

b) *5.1.5.2 COUNTER PHASE CONFIGURATION*

Sequence of oil flow

a2 → b1

b2 → a1

Where a2 = c1 outlet

b2 = c2 inlet

b1 = c2 outlet

a1 = c1 inlet

The 4/2 way valve will control the flow according to the above sequence. This is the counter phase configuration of our design.

**B. LINKS AND JOINTS**

Links and joints used in this project are movable link. The joints are fixed and rotary joints to achieve the steering conditions.

1) *MOVABLE LINKS*

Movable links are used to connect the rack and pinion and the piston rod of cylinder 1. It has two links on two sides of the cylinder. Then it has two links on either side to connect with the front axle. These links are king pin of the steering system. They are also used to connect the hydraulic cylinder 2 and the rear wheel axle. In these connections, the links used to connect are king pins as similar to the front axle.

2) *FIXED LINKS*

In this design, the fixed links are the front wheel axle and the rear wheel axle of the vehicle.

3) *FIXED JOINTS*

Fixed joints are used in the piston rods of the cylinder 1 and rack ends of the steering mechanism.

4) *ROTARY JOINTS*

These joints are used to provide the steering functions. These are rotating about y - axis of the vehicles to fulfil the steering functions.

**C. DESIGN AND SIMULATION**

We are design the model in Solidworks 2013. We are using existing rack and pinion model and attach the links and joints according to our design.

1) *CONSTRUCTION OF THE PROJECT*

The rack and pinion mechanism is attached with the front axle of the vehicle. The hydraulic double acting cylinder 1 is mounted with the body and piston rods are connected by a fixed joints to the rack. The cylinder 2 is mounted in the body closer to the rear axle. The ends of the piston rods are connected to the rear wheels through rear axle king pins as similar to the front axle. The valves of the cylinder 1 is named

as a1 and a2 and similarly the valves of cylinder 2 is named as b1 and b2 to left and right side respectively. The rack is joined with the king pin using the joints J3 and J4. The piston rod is connected by links L1 and L2 by joints J5 and J6 and then by J3' and J4'. The king pin is joined with the wheel axle by joints J1 and J2. The joints J3', J4', J5 and J6 are fixed joints. The valves a1, a2, b1 and b2 are connected to the 4/2 way valve through hoses. The piston of the cylinder 2 is connected to the king pin by the joints J7 and J8. It is connected to the rear axle by the joints J9 and J10. All the joints are rotary joints. The links L3 and L4 are king pin for rear wheel steering.

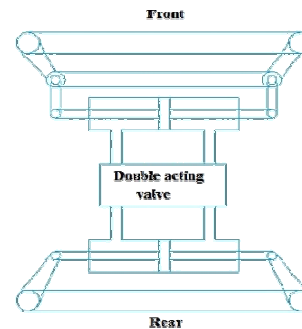

Construction diagram

2) *SOLIDWORKS MODEL*

In Solidworks 2013 software, the commands like drawing tools, hole wizard, extrusion, extrusion cut, fillet, mate tools to assemble and limit the movement of parts, mirror, move, rotate are used to create the model and simulate the links. The created solidworks model is shown in the figure.

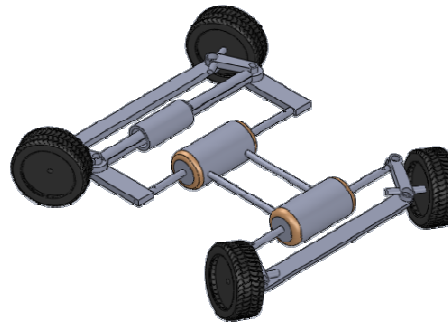

Left turn at counter phase condition

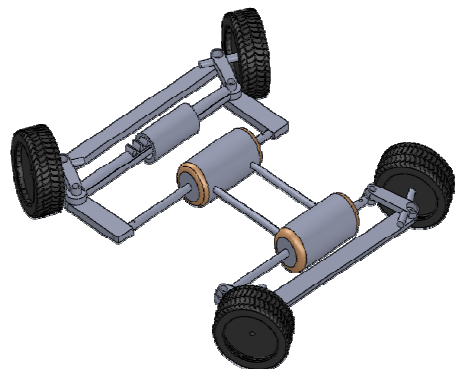

Right turn at counter phase condition

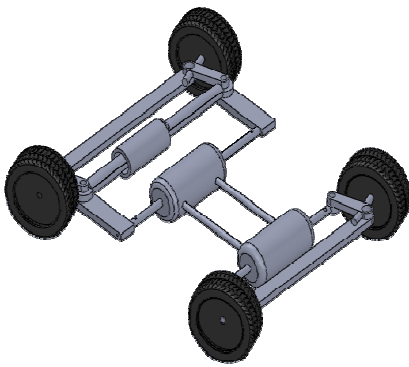

Left turn at in-phase condition

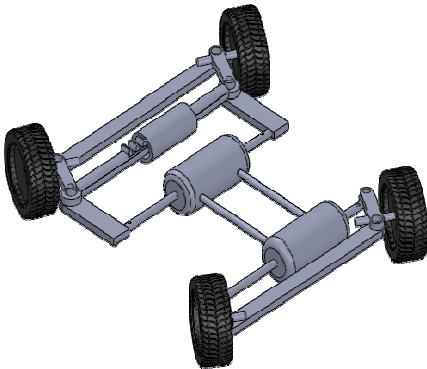

Right turn at in-phase condition

#### D. WORKING METHODOLOGY

The system is working as the existing steering mechanism in the front wheel. When the rack in the steering mechanism moves, the links L1 and L2 with fixed joints moves the piston rod of the cylinder 1. By this movement the compressed oil filled in the cylinder moves through the hose and then valve and actuate the cylinder 2. The links L3 and L4 connected with the piston rod of the cylinder 2 produce the steering function in the rear axle. The hydraulic valve sequence for in-phase configuration is  $a2 \rightarrow b2$  and then  $b1 \rightarrow a1$ . The sequence of valve for the counter-phase configuration is  $a2 \rightarrow b1$  and then  $b2 \rightarrow a1$ . This sequence is toggled by the 4/2 way valve which has 4 valves and two flow configuration. The 4 valves are connected with the cylinder 1 and cylinder 2 valves to control the flow. The toggling lever is connected to the gear shift lever to automatically toggle the flow configuration at slow and high speeds.

#### VI. CONCLUSION

Four wheel steering is a relatively new technology, that improves steering response in cars, trucks and trailers than standard two wheels steering vehicles, the rear set of wheels are always directed forward therefore the two wheel steering do not play an active role in controlling the steering. In four wheeled steering system the rear wheel can turn left and right. Thus four wheel steering keep the driving controls as simple as possible.

##### A. FUTURE SCOPE

This design is working with

- Low cost than the existing electronic systems.
- Possibility of failure of steering system is

overcome in this design even the rear wheel steering fails.

The future scope of this design is to overcome

- Oil leaks.
- Modification in floor of the car body is required.

#### REFERENCES

- [1] Shibahata Y, Irie N, Itoh H and Nakamura K (1986), "The Development of an Experimental Four-Wheel-Steering Vehicle", SAE 860623.
- [2] Thomas W Birch (1987), "Automotive Suspension and Steering System".
- [3] Vlk F (2001), "Dynamika Motorových Vozidel", Nakladatelství
- [4] Brabec P, Maly M and Vpzenilek R (2004), "Control System of Vehicle Model with Four Wheel Steering", International Scientific Meeting Motor Vehicles & Engines, Kragujevac.
- [5] Tom Murphy and Brian Corbett (2005), "Quadra Steer Off Course"
- [6] Johnson Erik (2007), "2008 Infiniti G37 Sport Coupe-Suspension, Handling and Four-Wheel Steering".
- [7] Jack Erjavee (2009), "Automotive Technology-A System Approach", Cengage Learning, 5th Edition.
- [8] Kirpal Singh (2011), Automobile Engineering, 12th Edition, pp. 207-229, Standard Publication Distributors.
- [9] K. Lohith, Dr. S. R. Shankapal, M. H. Monish Gowda (2013) 'Development of Four Wheel Steering system for a car', SAS TECH Journal, Volume 12, Issue 1.
- [10] Tim Gilles (2014), "Automotive Service- Inspection, Maintenance, Repair".
- [11] Arun singh, Abhishek kumar, Rajiv Chaudhary, R. C. Singh (2014) 'Study of 4 Wheel Steering Systems to Reduce Turning Radius and Increase Stability', ICARI.
- [12] Aman Doraya, Mohit Singh Panesir, Bhavya Bhardwaj, Aditya Bochara '4-Wheel Steering System Mechanism using DPDT Switch', IJMET, Volume 6, Issue 11, November 2015
- [13] [http://trucks.about.com/cs/4ws/a/4wheel\\_steering.htm](http://trucks.about.com/cs/4ws/a/4wheel_steering.htm)
- [14] <http://www.delphiauto.com>
- [15] <http://www.howstuffworks.com>
- [16] <http://www.theautochannel.com>
- [17] <http://www.grabcad.com>