

# RENEWABLE ENERGY: EFFECTIVE USE OF SOLAR ENERGY BY INTELLIGENT BATTERY CHARGING TECHNIQUE

S.Sudharshanan

P.G Scholar, Department of Electrical and Electronics Engineering

Anna University Regional Centre, Coimbatore, Tamilnadu, India

A.Anbalagan

P.G Scholar, Department of Electrical and Electronics Engineering

Anna University Regional Centre, Coimbatore, Tamilnadu,India

**Abstract---**This present scenario we are facing a large amount of power crisis in our country to counteract this problem we are going for renewable energy, even though we are generating a power from solar and wind now no technique has been developed for efficient battery charging in PV/Grid connected solar UPS. This project deals with intelligent battery charging technique using SOC(State Of Charge) estimation so as to enhance the effective power utilization of solar panels and also the battery life.

**Keywords-**Effective battery charging, State of charge (SOC)

## 1 . INTRODUCTION

In the current scenario, there is an acute power shortage in India. In order to overcome the energy crisis people have started to harness renewable energy sources. Among all the renewable energy sources, solar and wind energy are highly used. India being a tropical country, solar energy is abundantly available. Till now no

technique has been developed for efficient battery charging in PV/Grid connected solar UPS. Thus power utilization of solar panels is very low. It is only around 20% to 30%.This project deals with intelligent battery charging technique using SOC(State Of Charge) estimation so as to enhance the effective power utilization of solar panels and also the life of the battery. A new layout is developed replacing the conventional layout of the PV/Grid connected Solar UPS. In the present layout, the AC supply is fed through a switch and a buck converter so as to use the AC supply only when it is required. According to this algorithm, the AC is connected to the load only if the Battery SOC falls below 70%. Hence, the battery will be charged by the Solar power only when the battery SOC is above 70% thus increasing power utilization of the solar panel.

### 1.1 PROPOSED BLOCK DIAGRAM

In the proposed layout, the Solar panel is not directly fed to the Battery. Instead it is fed through

- An MPPT (Maximum Power Point Tracking) Unit
- Charge Controller

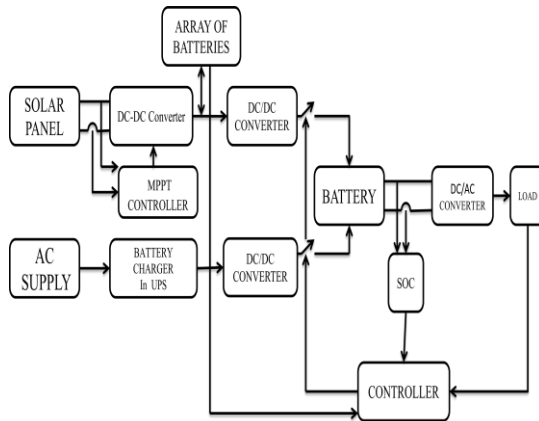

Figure 1.1A Block diagram of the proposed layout

### 2. MPPT (Maximum Power Point Tracking) controller

The MPPT Controller is used to obtain the Maximum power available at that instant from the Solar panel. The MPPT technique is achieved by varying the duty cycle of the MOSFET. There are many algorithms available to realize the MPPT. In this project **Perturb & Observe** Algorithm has been used. The output of the MPPT controller is the duty cycle which is given to the MOSFET of the boost converter. In this the Perturb and Observe algorithm is used. The P&O algorithm is also called “hill-climbing” algorithm. In this method, the change in power with respect to the change in voltage is monitored. The present perturbation is desired by the sign of the power during the last perturbation ,the present perturbation must continue in the same direction else if the change in power is negative during the last perturbation, the present perturbation must continue in the opposite direction .

The DC-DC converter is an electronic circuit which converts a source of direct current (DC) from one voltage level to another. In our project we are using a boost converter used when higher output voltage required than DC signal from solar panel.

The output voltage equation is

$$V_o = V_s \left( \frac{1}{1-D} \right)$$

$V_o$  – Is the average output voltage

$D$ —Is the duty cycle

$V_s$  – Is the input voltage from source

By varying the gate pulse given to the boost converter, the output voltage varies. The variable gate pulse is provided by a microcontroller according the P&O algorithm and MPP is tracked by varying the output voltage.

**Figure 2.1: MATLAB/Simulink model for MPPT unit LOAD = 100 Ω**

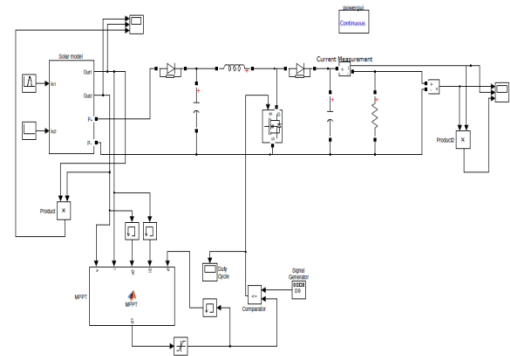

### Simulation results:

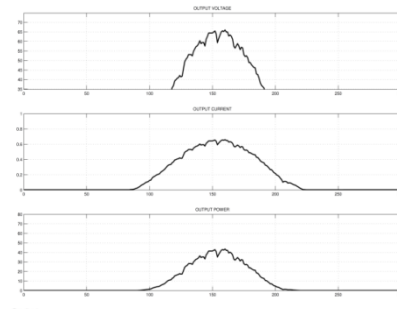

Figure 1.2.3: Output of the solar model without MPPT

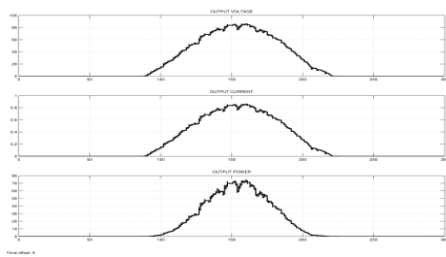

Figure 1.2.4: Output of the solar model with MPPT

### Inference:

Peak power delivered by the solar panel without MPPT system = 40 W

Peak power delivered by the solar panel with MPPT system = 70 W

$$\text{Difference in power} = 70 - 40 = 30\text{W}$$

### 3. Array of batteries

The output of the boost converter is fed to an array of batteries. It is another innovation in this project which is used to enhance the power utilization as well as the life of the Batteries. The output voltage of the MPPT Unit is highly fluctuating. Thus the sizing of battery for the MPPT unit is a challenging task. If Battery is sized for lower voltages, the Battery will be over-charged which could reduce the life of the Battery. If Battery is sized for higher voltages, the Battery will remain unchanged at most of the time. Connecting the required number of batteries to the system based on the output voltage will the operation of breakers corresponding to the output voltage of the MPPT system at that instant. The Output voltage of the MPPT varies from one

solve this issue. Thus in the proposed layout, the number of batteries connected to the output of the MPPT system at any instant depends only on the output voltage of the boost converter at that instant. Thus, the life of the batteries and the Charging of batteries are enhanced.

### 4. Charge controller

The Charge Controller is used to provide a Constant voltage Constant current charging to the battery. It is accomplished by providing a variable duty cycle to the DC-DC converter. It is accommodated to enhance the life of the battery. Similarly the AC supply is fed to the Battery through a Switch and a charge controller. The Switch is controlled by the Switching controller of the battery which is another important task in this project.

### 5. Switching controller

The Switching Controller controls the connecting and disconnecting the AC supply by a switch. An algorithm has been developed to operate this switch which requires the measurement of SOC (State of Charge)

### 6. MATLAB/Simulink Model

In the MATLAB model, six batteries have been incorporated in the array. The number of batteries connected to the system at any system to the other depending on the load. Hence, the number of batteries in the array, voltage rating of the batteries varies.

#### 6.1 MATLAB/Simulink Model

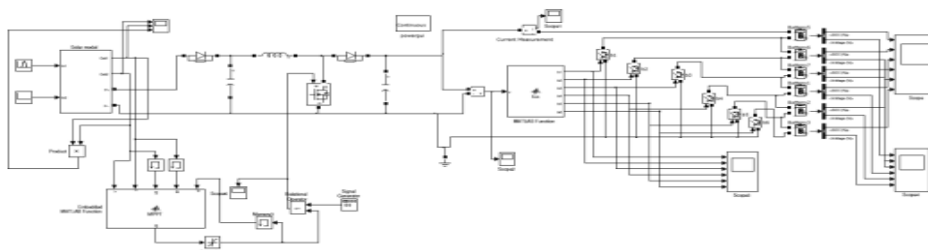

Figure 6.1 MATLAB/Simulink model for MPPT unit with array of batteries

### 6.1.A Simulation results

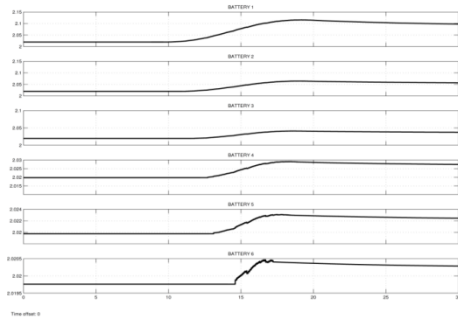

Figure 6.1.A1 Terminal voltage of all the batteries in the array

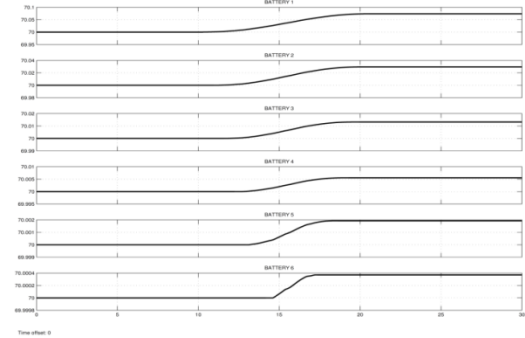

Figure 6.1.A4 SOC of all the batteries in the array

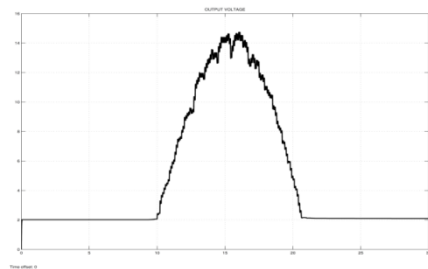

Figure 6.1.A2 Output voltage of MPPT unit

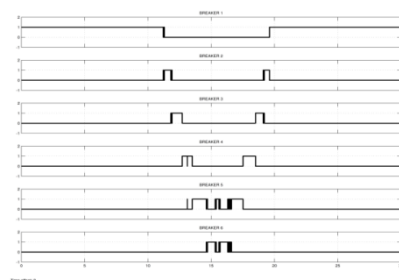

Figure 6.1.A3 Operation of the Breakers

- The Breakers are operated depending on the output voltage at that instant
- The SOC and voltage of the Batteries vary accordingly

## DETERMINATION OF SOC

### 7. State Of Charge

State of Charge (SOC) is the amount of energy left in a battery compared with the energy it had when it was full. The SOC is defined as the available capacity expressed as a percentage of its rated capacity. There are many methods available for estimation in that voltage based soc estimation is used because of its simple calculation.

#### 7.1 Voltage Based SOC Estimation

This uses the voltage of the battery cell as the basis for calculating SOC or the remaining capacity. Results can vary widely depending on actual voltage level, temperature, discharge rate and the age of the cell and compensation for these factors must be provided to achieve a reasonable accuracy. The following graph shows the relationship between the Open Circuit Voltage

From the above graphs, it is clear that,

and the Remaining Capacity at constant temperature and discharge rate for a high capacity Lead Acid cell. Note that the cell voltage diminishes in direct proportion to the remaining capacity

### 8. Development Of MATLAB/Simulink

#### Model

The Determination of Battery SOC requires the measurement of Terminal voltage of the Battery and the Charging/Discharging current at that instant. In the MATLAB model, 12V, 150 Ah Battery has been incorporated. The SOC of the Battery at some standard values of current and voltages are obtained by simulating in MATLAB model

The tabulation given below is the characteristics of the 12 V, 150 Ah Battery at the given Voltage and Charging/Discharging current.

	AT DISCHARGING				
	Voltage e (C/100 )	Voltage e (C/20)	Voltage e (C/10)	Voltage e (C/5)	Voltage e (C/3)
10	9.09	9.09	9.079	9.05	9.012
20	10.85	10.85	10.84	10.83	10.8
30	11.44	11.44	11.43	11.42	11.39
40	11.74	11.73	11.73	11.71	11.67
50	11.91	11.91	11.90	11.89	11.86
60	12.03	12.03	12.02	12.01	11.96
70	12.11	12.11	12.10	12.09	12.06
80	12.18	12.17	12.17	12.15	12.11
90	12.23	12.22	12.22	12.2	12.18
100	13.08	13.08	13.07	13.04	12.97

#### Standard values of Battery SOC during charging & floating condition

From the tables 8.1 & 8.2, the SOC at the given voltage & current are known. The SOC have to be calculated if the voltage and current lies in between these values.

SOC	AT FLOAT State	AT CHARGING			
		Voltage e (C/40)	Voltage e (C/20)	Voltage e (C/10)	Voltage (C/5)
10	9.109	9.169	9.22	9.33	9.521
20	10.86	10.92	10.98	11.09	11.27
30	11.45	11.51	11.57	11.67	11.86
40	11.74	11.80	11.86	11.97	12.16
50	11.92	11.98	12.04	12.15	12.34
60	12.03	12.10	12.16	12.27	12.48
70	12.12	12.18	12.25	12.37	12.58
80	12.18	12.25	12.32	12.45	12.68
90	12.23	12.31	12.39	12.53	12.80
100	13.09	13.15	13.20	13.32	13.56

Table 8.1 and 8.2 SOC during charging and discharging condition

- For the 12 V, 150 Ah battery,

If the Terminal voltage is 11.27 V and current is 30 A (Charging), the SOC is 20% (from the table).

If the Terminal voltage is 11.5 V (lies between 11.27 V and 11.86 V) and current is 30 A (Charging), the SOC is determined as follows:

$$SOC = \left\{ \frac{30-20}{11.86-11.27} \times (V - 11.27) \right\} + 20 \tag{8.1}$$

where,

30 - SOC of the Battery when the Terminal voltage is 11.86 V

20 - SOC of the Battery when the Terminal voltage is 11.27 V

V - Terminal voltage of the Battery at which the SOC is to be determined

- If the Terminal voltage is 11.5 V (lies between 11.27 V and 11.86 V) and current is 20 A (Charging) [lies between 30 A and 15 A], the SOC is determined as follows:

To determine the SOC when both Terminal voltage & Current are not standard values, the

Terminal voltages are found for the given current by the above method.

As there are 10 rows for a given value of current, 10 rows of terminal voltages for the given value of current using the voltages at standard values of current will be obtained.

$$V1 = \left\{ \frac{9.521-9.33}{\left(\frac{C}{5}\right)-\left(\frac{C}{10}\right)} \times \left( I - \left( \frac{C}{10} \right) \right) \right\} + 9.33 \quad (8.2)$$

$$V2 = \left\{ \frac{11.27-11.09}{\left(\frac{C}{5}\right)-\left(\frac{C}{10}\right)} \times \left( I - \left( \frac{C}{10} \right) \right) \right\} + 11.09 \quad (8.3)$$

$$V3 = \left\{ \frac{11.86-11.67}{\left(\frac{C}{5}\right)-\left(\frac{C}{10}\right)} \times \left( I - \left( \frac{C}{10} \right) \right) \right\} + 11.67 \quad (8.4)$$

$$V4 = \left\{ \frac{12.16-11.97}{\left(\frac{C}{5}\right)-\left(\frac{C}{10}\right)} \times \left( I - \left( \frac{C}{10} \right) \right) \right\} + 11.97 \quad (8.5)$$

$$V5 = \left\{ \frac{12.34-12.15}{\left(\frac{C}{5}\right)-\left(\frac{C}{10}\right)} \times \left( I - \left( \frac{C}{10} \right) \right) \right\} + 12.15 \quad (8.6)$$

$$V6 = \left\{ \frac{12.48-12.27}{\left(\frac{C}{5}\right)-\left(\frac{C}{10}\right)} \times \left( I - \left( \frac{C}{10} \right) \right) \right\} + 12.27 \quad (8.7)$$

$$V7 = \left\{ \frac{12.58-12.37}{\left(\frac{C}{5}\right)-\left(\frac{C}{10}\right)} \times \left( I - \left( \frac{C}{10} \right) \right) \right\} + 12.37 \quad (8.8)$$

$$V8 = \left\{ \frac{12.68-12.45}{\left(\frac{C}{5}\right)-\left(\frac{C}{10}\right)} \times \left( I - \left( \frac{C}{10} \right) \right) \right\} + 12.45 \quad (8.9)$$

$$V9 = \left\{ \frac{12.8-12.53}{\left(\frac{C}{5}\right)-\left(\frac{C}{10}\right)} \times \left( I - \left( \frac{C}{10} \right) \right) \right\} + 12.53 \quad (8.10)$$

$$V10 = \left\{ \frac{13.56-13.32}{\left(\frac{C}{5}\right)-\left(\frac{C}{10}\right)} \times \left( I - \left( \frac{C}{10} \right) \right) \right\} + 13.32 \quad (8.11)$$

C - Ampacity of the Battery (Ah)

Where,

V1 to V10 are the Terminal voltages of the Battery at the current 40 A.

The SOC is determined by identifying the range in which the measured terminal voltage of the battery falls (ie. identifying V from V1 to V10).

For instance,

If the measured terminal voltage V lies between V2 and V3, the SOC is obtained as follows:

$$SOC = \left\{ \frac{30-20}{V3-V2} \times (V - V2) \right\} + 20 \quad (8.12)$$

By incorporating the above logic in MATLAB model, the SOC at any instant of the Battery is obtained. The Terminal voltage, Current (Charging/Discharging) and the capacity(Ah) of the Battery is given as the input to the system and the obtained SOC of the Battery is displayed. Thus on measuring the required parameters and feeding those as inputs, the above system could be incorporated in this project for the switching ON/OFF of AC supply.

### 9. MATLAB/Simulink model

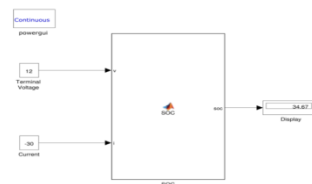
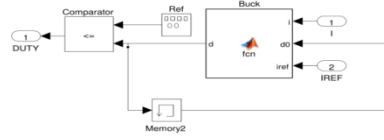
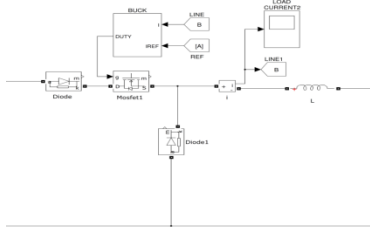

Figure 9.1 MATLAB/Simulink model for SOC estimation

### 10.MATLAB/Simulink model for Charge controller



**10.1 Simulation results**

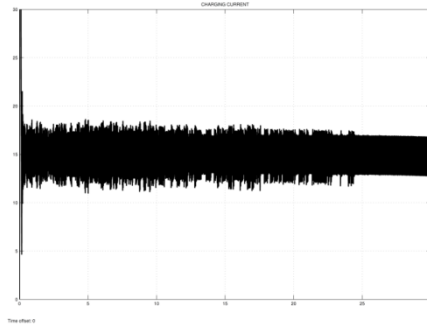

Figure 10.1.1 Charging current  
For a 12 V, 150 Ah battery, the rated Charging current is 15 A.

Thus, the Charging current is maintained around 15 A.

**11.Overall MATLAB model**

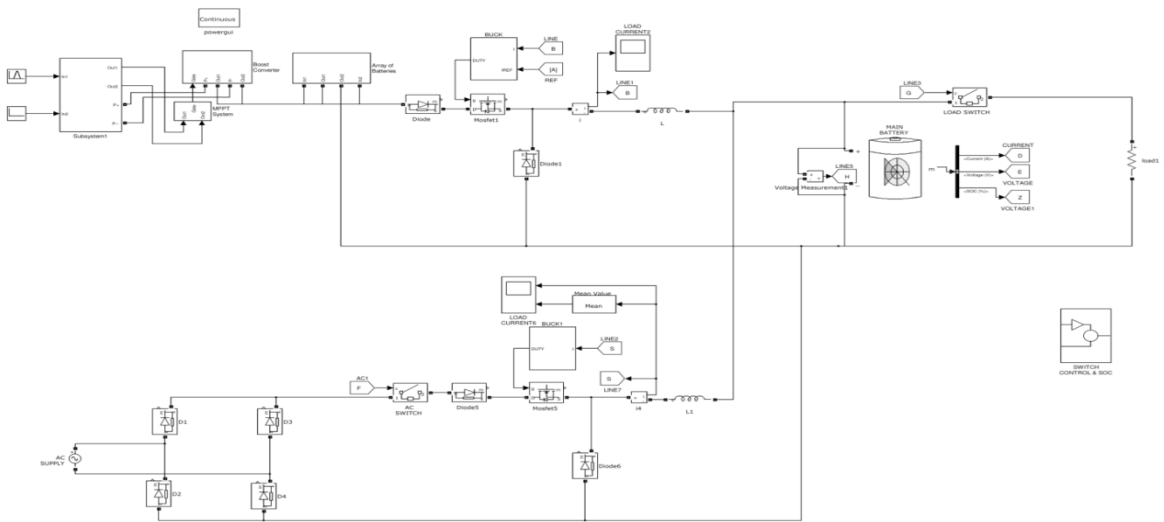

Figure 11.1 Overall MATLAB/Simulink model of the project

### 11.1A Simulation results

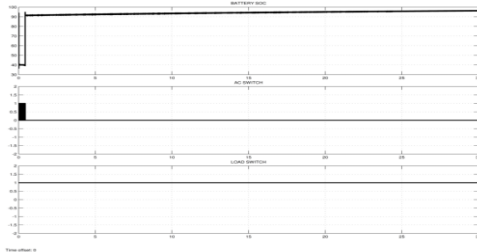

Figure 11.1A Operation of switch when Battery SOC>40%

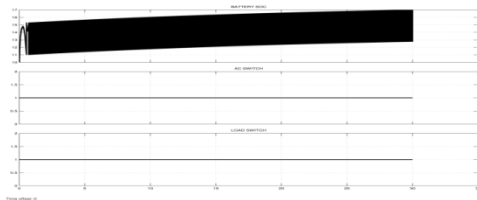

Figure 11.1B Operation of switch when Battery SOC<40%

### 12. CONCLUSION

Thus the Intelligent switching technique has been developed using the microcontroller. The SOC is estimated using the voltage measurement and the corresponding values are fed to the microcontroller and the switches are operated accordingly. By implementing this technique in the current PV/Grid connected UPS, the effective power utilization of the solar panel can be improved from 20% to 80%. This work can be extended by implementing a power management controller instead of the switching controller by acquiring the basic idea from this report. The power management controller should control

the current flow from the AC supply depending on the load demand which should be estimated dynamically at every instant by the controller which could further improve the power utilization of the solar panel.

### REFERENCES

1. Li S.G, Sharkh S.M, Walsh F.C and Zhang C.N (2011) 'Energy and Battery Management of a Plug-In Series Hybrid Electric Vehicle using Fuzzy logic', IEEE Tran. Vehicular., vol. 60, no. 8, pp no. 3571-3585.
2. Pradeep kumar P and Kiran babu B. (2012), 'Power-Management strategies for a Grid-Connected PV-FC Hybrid system by using fuzzy logic controller', IJMER, vol. 2, no. 2, pp. 358-364.
3. Singh et al S.N (2011), 'Rural Home Energy Management by Fuzzy control model for Utility interfaced Autonomous Solar/DG Power system in India', IJAEST, vol. 4, no. 1, pp. 015-021.
4. Tao Sun and Jian- Jun Shi (2010), 'Fuzzy Control based Energy Management Strategy for combined Power System', in Proc. 2nd Pacific-Asia Conf. IEEE Cir., Comm. and Sys., vol. 2, pp no. 105- 108.
5. Tao Zhou and Bruno Francois (2011), 'Energy Management and Power Control of a Hybrid Active Wind Generator for Distributed Power Generation and Grid Integration', IEEE Trans. Ind. Electron., vol. 58, no. 1, pp no. 95- 104.
6. Valarmathi R., Palaniswami S., Devarajan N (2012) 'Simulation and Analysis of Wind energy and Photo voltaic Hybrid system', International Journal of Soft Computing and Engineering, vol. 02, no. 02, pp no. 193- 200.