

BORDER ALERT AND SMART TRACKING SYSTEM WITH ALARM USING DGPS AND GSM

NaveenKumar.M^{#1}, Ranjith.R^{*2}

^{**}Department of Electronics and Instrumentation Engineering,

^{**}Sri Sairam Engineering College, Chennai, Tamilnadu, India.

naveenkumarmohanasundaram@yahoo.in^{#1}, ranjithr2901@gmail.com^{*2}

ABSTRACT—Increasing tensions across the Indian and Sri Lankan borders caused much havoc between the two countries. Fishermen from our country are being abducted by the Srilankan navy for crossing the border which is unintentional most of the times. The paper deals with a system of tracking the location of the boat using DGPS and to trigger an alarm which consists of a Piezo-buzzer, when the border is approached or crossed. Also, in addition, the DGPS information is sent to control room where it is read and then through a GSM device, information is sent to the family at regular time intervals who are in anticipation about their family member's safety. The paper aims at providing a system that will alert the fishermen well in advance and ensure maximum safety and peace at the borders and also notify the family members.

Index Terms—DGPS, GSM, Piezo-buzzer, Latitude, Longitude.

I. INTRODUCTION:

Global Positioning system (GPS) provides a wide range of navigation and timing services. With the combined interlocked usage of the GSM technology, it can be used for border security, tracking of boats and ships in the oceans and in the seas. The current issue of Indian fishermen being abducted by the Srilankan navy is of serious concern. This paper serves as a benefit for these people where a DGPS system is attached to the boat which in turn is connected to an alarm device. The DGPS receives the topographic location of the boat in the sea and then triggers an alarm if the border of the country is crossed by the boat. Topographic location of a country's border can be obtained with the information of the

latitude and longitude of the place and position of the boat. The borders of each country are defined in two levels. The first level extends till a certain distance in the sea and it is called as the National border of the country. Succeeding the national borders and just a few kilometers towards is the International borders. The additional advantage from the existing border alert systems that are already imparted is that, the interlock of the GSM where minute by minute position of the boat can be received through an SMS to the family members from the control room through the use of DGPS. But, earlier systems employed infrared radiations which proved to be quite disadvantageous and difficult to use. The DGPS report is also sent to the control room from which the location of the boat can be tracked, in case it is lost in the seas. The paper uses a GPS device, GSM, microcontrollers and an alarm system to alert the fishermen whenever the border is crossed by unauthorized means. [3]The number of fisherman abducted by the srilankan navy scenario is shown below:

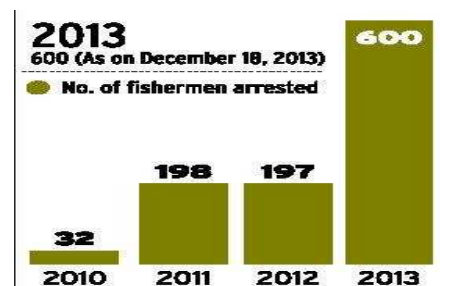

Fig 1.No. of Maritime Border Crossing Issue

[2]The existing system is a low cost maritime border crossing alert system mainly focused on the small scale fisherman who lives just near to the poverty line. This system includes data collection unit, processing unit, controlling unit and

transmission unit as shown in fig 2. The data collection unit consists of location detection components like GPS, transmitter and other components attached in the boat that accomplishes the vessel localization by collecting the geographical positions. The processing unit holds the set of latitude and longitude values of the sea in the form of databases that can be used for comparing the present boat position with legal border limits. The controlling unit resides in the sea shore (remote station) from where the decision has been made if the vessel crossed the maritime border. All the communication among these three units is handled by transmission unit. The proposed system's detailed work flow is discussed in the following sections.

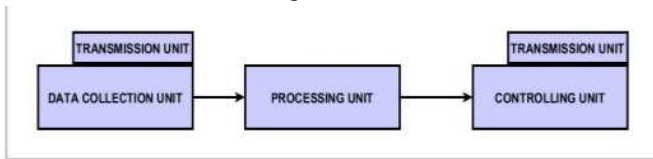

Fig.2 Block diagram of the existing system

II.SYSTEM ARCHITECTURAL DESIGN OF THE SMART TRACKING SYSTEM

The proposed architectural design consists of a DGPS device which is interfaced to the 8051 Microcontroller which in turn is connected to the alarm circuit. The DGPS information tracked in the control room is sent to family members through a GSM system and the information is immediately sent to the border security and the necessary action is taken.

The design and function of each block is explained below:-

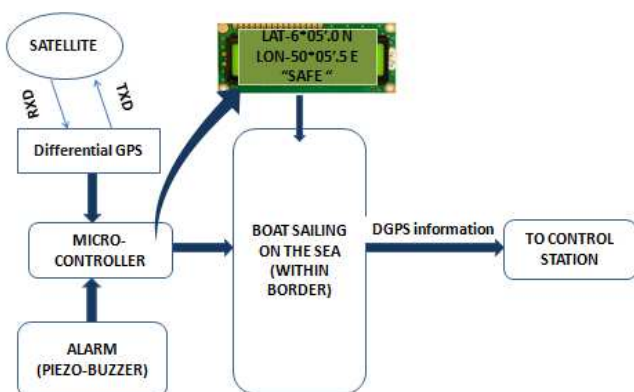

Fig 3. Block diagram of proposed tracking system on safe mode

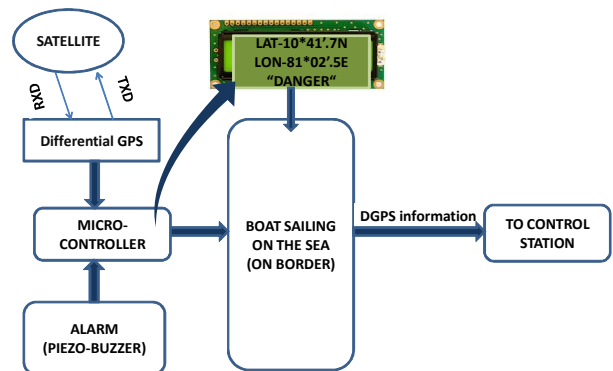

Fig 4. Block diagram of proposed tracking system on danger mode

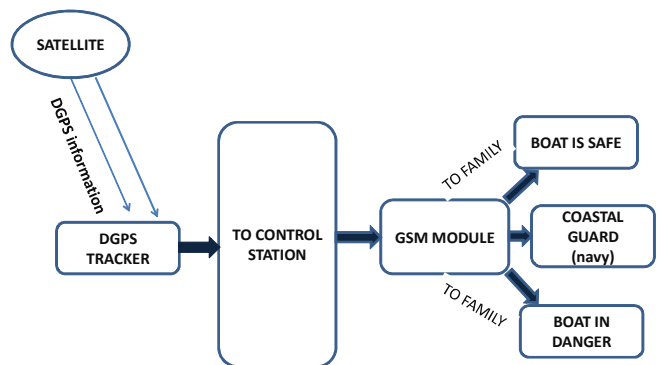

Fig 5. Block diagram of proposed tracking system

A. GLOBAL POSITIONING SYSTEM DEVICE:

The Global Positioning System (GPS) is a space-based satellite navigation system that provides location and time information in all weather conditions. The Global positioning system basically consists of two parts: Transmitter and Receiver. The transmitter's job is to track the location with the help of information from satellite. The satellite information is taken and this is sent to the receiver where the exact longitude and latitude of the place is found. The working of GPS is explained as follows. First, the signal is transmitted to the satellites and the time taken for transmission

is calculated. Depending on the time taken, the latitude and longitude information is fed into the receiver.

Each GPS satellite transmits data that indicates its location and the current time. All GPS satellites synchronize operations so that these repeating signals are transmitted at the same instant. The signals, moving at the speed of light, arrive at a GPS receiver at slightly different times because some satellites are further away than others. The distance to the GPS satellites can be determined by estimating the amount of time it takes for their signals to reach the receiver. When the receiver estimates the distance to at least four GPS satellites, it can calculate its position in three dimensions.

B. DIFFERENTIAL GLOBAL POSITIONING SYSTEM DEVICE:

Differential Global Positioning System (DGPS) is an enhancement to Global Positioning System that provides improved location accuracy, from the 15-meter nominal GPS accuracy to about 10 cm in case of the best implementations.

Its accuracy is about of +/-1m.

WORKING—DGPS uses a network of fixed, ground-based reference stations to broadcast the difference between the positions indicated by the satellite systems and the known fixed positions. These stations broadcast the difference between the measured satellite pseudo ranges and actual (internally computed) pseudo ranges, and receiver stations may correct their pseudo ranges by the same amount. The digital correction signal is typically broadcast locally over ground-based transmitters of shorter range.

A reference station calculates differential corrections for its own location and time. Users may be up to 200 nautical miles (370 km) from the station, however, and some of the compensated errors vary with space: specifically, satellite ephemeris errors and those introduced by ionospheric and tropospheric distortions. For this reason, the accuracy of DGPS decreases with distance from the reference station. The problem can be aggravated if the user and the station lack "inter visibility"—when they are unable to see the same satellites.

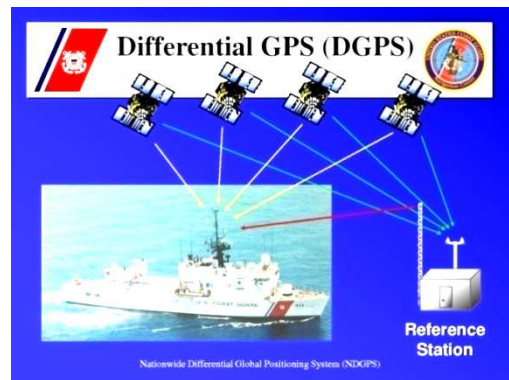

Fig 6. Differential Global Positioning System

C. 8051 MICROCONTROLLER:

The 8051 Microcontroller chip INTEL- AT89C51 is being employed in the project. The main use of this microcontroller is to take the data from the DGPS device and transfer the information to the microcontroller. The information is stored in the microcontroller EPROM and then depending on the border information the alarm circuit is triggered and this alerts the people. The information is also sent to the control room and to the family.

The pin description of ATMEL 89C51 microcontroller is shown below:-

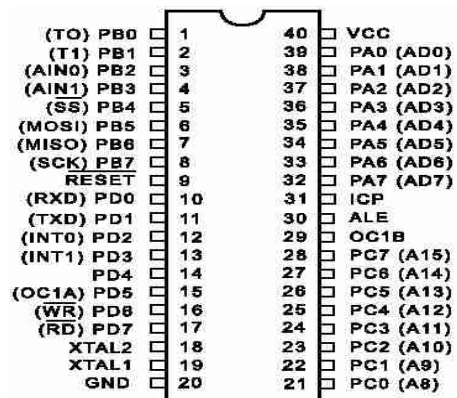

Fig 7. Pin Description of ATMEL 89C51 microcontroller.

D. ALARM CIRCUIT:

Buzzer is used to indicate that the boat has crossed the border. Under normal conditions, i.e., when boat is inside country's border, current flows through emitter. And hence, buzzer is not activated. When boat crosses border, circuit is closed and

current flows to buzzer. Thus alarm is generated.

E. GSM DEVICE:

GSM refers to Global system for mobile communication which is the key factor in this paper to inform about the where-about of the fishermen in the vast seas. The control room output is taken and it is fed into the GSM where, the information is sent to the mobile phones of the family members through SMS, informing them about the status. In case the boat is lost due to rough conditions of the sea (or) intentional crossing of the border is done, then the information is immediately sent to the border security and the necessary action is taken.

WORKING—The working of the GSM system in place is very simple. Here the GSM is placed in the control station. The control station continually receives the GPS information of each boat through the unique GPS address. This address is linked up with the GSM system and then gets the information. Now, the main use of this GSM is to alert the family members of the fishermen who have gone into the seas of their situation.

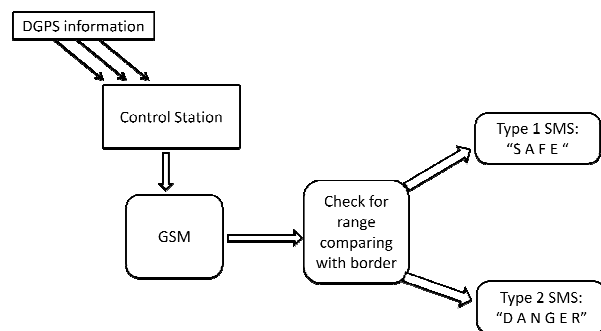

Fig 8. Block diagram representation of the working of GSM in the paper.

There are two types of SMS that will be sent to the family. The GSM will have an inbuilt storage and it will compare the DGPS value with the standard values already fixed by the authorities. Depending upon this comparison, the types of messages sent will be 'SAFE' and 'DANGER'. So, this system proves to be worthwhile in helping the family also keep update in regular time intervals.

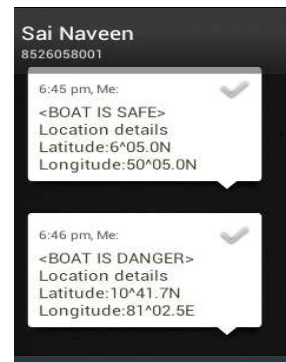

Fig 9. Sample Message Alert To Family Members

III. IMPLEMENTATION OF THE SYSTEM

The architectural views of the project were discussed earlier and the system implementation is discussed below. The main systems to be implemented are the interface of the DGPS circuit with the 8051 microcontroller and the ALARM to it. The other interface would be the retrieval of the DGPS information from the device and then latching it with the GSM system and sending the SMS.

A. INTERFACING THE GPS DEVICE WITH 8051 MICROCONTROLLER:

The GPS module continuously transmits serial data (RS232 protocol) in the form of sentences according to NMEA standards. The latitude and longitude values of the location are contained in the GPGGA sentence.

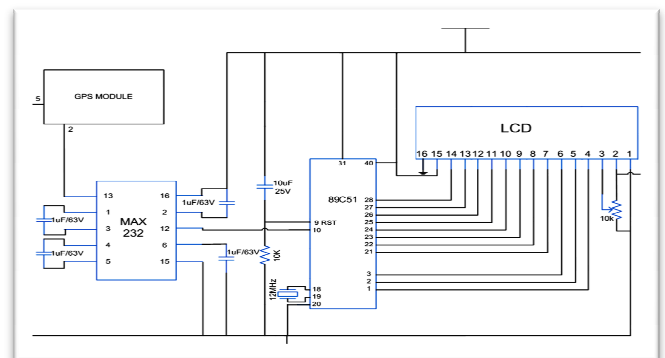

Fig 10. Interfacing the GPS module with 8051 microcontroller.

In this program, these values are extracted from the GPGGA sentence and are displayed on LCD. The serial data is taken from the GPS module through MAX232 into the SBUF

register of 8051 controller. The serial data from the GPS receiver is taken by using the serial interrupt of the controller. This data consists of a sequence of NMEA sentences from which GPGGA sentence is identified and processed. The first six bytes of the data received are compared with the pre-stored (\$GPGGA) string and if matched then only data is further accounted for; otherwise the process is repeated again. From the comma delimited GPGGA sentence, latitude and longitude positions are extracted by finding the respective comma positions and extracting the data. The latitude and longitude positions extracted are displayed on the LCD interfaced with AT89C51. To obtain more details (other than latitude and longitude) from the GPS receiver, GPRMS sentence can be used. The circuit connections are as follows: Receiver1 (R₁) of MAX232 has been used for the serial communication. The receiver pin of GPS module is connected to R₁IN (pin13) of MAX232. R₁ OUT (pin 12) of MAX232 is connected to RxD (P3.0) of AT89C51. Pins 1-3 of port P1 (P1.0, P1.1 & P1.2 respectively) of AT89C51 are connected to the control pins (RS, R/W & EN) of LCD. The data pins of LCD are connected to Port P2 of the controller. The latitude and longitude positions are then displayed onto the 7-Segment LCD monitors.

B. INTERFACING THE ALARM CIRCUIT WITH THE 8051 MICROCONTROLLER:

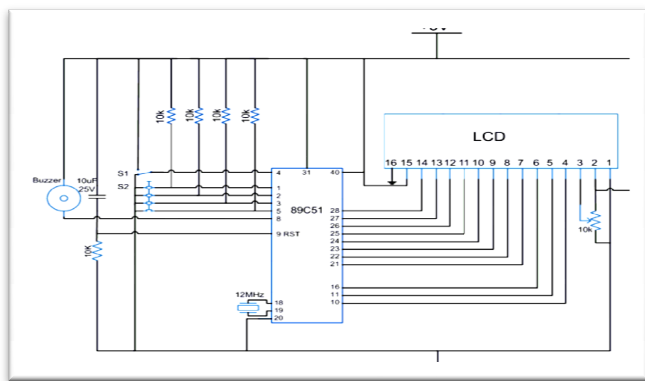

Fig 11. Interfacing the Alarm circuit (Piezo-buzzer) with the 8051 microcontroller.

The circuit diagram of the alarm interface with the 89C51 Microcontroller is shown above. The circuit is one of the main parts of the security system. The circuit is triggered only when a certain longitude and latitude is matched with the border's value that is already stored inside the EPROM. The values stored inside the memory are continuously matched with the current GPS values tracked by the device. The main idea of

the paper is to alert the fishermen, so the alarm circuit is triggered three times depending on the change of latitudes. The first level of security is when the boat/ship approaches the National borders and the second alarm is triggered when the national borders are crossed and when the boat by unauthorized means enter the International borders. At this time the 89C51 Microcontroller sends the signal to the alarm circuit and it is triggered. There are two switches S1 and S2 to propagate this action. Initially when there is no signal from the microcontroller, the switch S1 is connected and when the border is crossed the switch S1 is off and switch S2 is ON. Now, the Piezo-buzzer is activated and gives an alarm. The additional usage of this circuit is that the LCD interface. The LCD screen also will display and alert the fishermen in addition with the alarm. The connections are as follows: The Piezo-buzzer's one end is connected to the Pin 8 of the microcontroller and the other end connected to Pin 31 of the microcontroller. The 89C51 microcontroller is facilitated with the 12 MHz clock and the LCD interface is provided. The data pins of LCD are connected to Port P2 of the controller. The latitude and longitude positions are then displayed onto the 7-Segment LCD monitor display device.

IV. BOUNDARY LOCATIONS

The maritime boundary between Sri Lanka and India in the Bay of Bengal shall be arcs of great circles between the following positions, in the sequence given below, defined by latitude and longitude:

POSITIONS	LATITUDE	LONGITUDE
Position 1	10° 05'.0 N	80° 03'.0 E
Position 2	10° 05'.8 N	80° 05'.0 E
Position 3	10° 08'.4 N	80° 09'.5 E
Position 4	10° 33'.0 N	80° 46'.0 E
Position 5	10° 41'.7 N	81° 02'.5 E
Position 6	11° 02'.7 N	81° 56'.0 E
Position 7	11° 16'.0 N	82° 24'.4 E

Fig 12. Maritime boundary in Bay of Bengal

A.MARITIME BOUNDARY BETWEEN INDIA AND SRI LANKA:

ACKNOWLEDGMENT

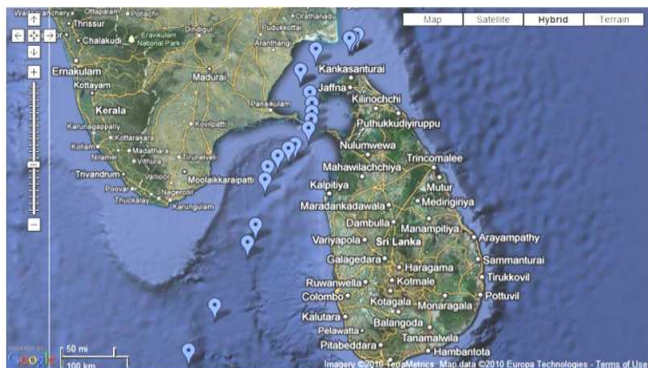

Fig 12.Graphical representation of border

The boundary points are marked above. These points are stored in microcontroller. The computation is done in microcontroller with these points. Thus any illegal crossing of boats can be identified and informed to the family and to control station

V. CONCLUSION

The proposed paper of the Border alert and smart tracking with alarm using DGPS and GSM has proven to be a low-cost project. The project also aims at providing peace at the borders and reduces the tensions between the two countries. The proposed system's architecture is reliable and robust. The greatest advantage of the DGPS system is the ability of the device to work in any weather conditions and in any means. The system devised will also include a waterproof casing such that the circuit is not prone to any damage. The system will provide high accuracy and high precision values of the Latitude and Longitude. This model proves to challenge the already existing model which just uses a DGPS device to track the border and make the boat move backwards. This is not as useful as, in the middle of the seas, even though there are no waves, the ocean currents can mislead the boat and lead to scrutiny. The system proposed will not only alert the fishermen but also carries the information to the control station and also notifies the family members through the GSM system. In case the boat is lost due to rough conditions of the sea (or) intentional crossing of the border is done, then the information is immediately sent to the border security and the necessary action is taken.

We express our heartfelt thanks to Mr.S.Abhinav Karthik, Mr.C.Surendar, and Mr.R.Natarajan for providing all the necessary materials for this paper.



We are very much thankful to Dr. K. Renganathan, M.Tech, PhD, HOD, Department of Electronics and Instrumentation of Sri Sairam Engineering College for providing moral support and constant encouragement.



We are very much thankful to Ms. K. Thirupura Sundari, M.E AP-I, and the Department of Electronics and Instrumentation of Sri Sairam Engineering College for providing their endless support and courage for bringing up this paper.

REFERENCES

- [1] K. Suresh Kumar et. al. / Design of low cost maritime boundary identification device using gps system/International Journal of Engineering Science and Technology Vol. 2(9), 2010, 4665-4672.
- [2] M Sivaramaganesh/International journal of innovative research in electrical, electronics, instrumentation and control engineering vol. 2, issue 3, march 2014.
- [3]http://www.thehindu.com/multimedia/dynamic/01689/TH_09_GROWING_rev__1689954g.
- [4] S. Mani Sunder/Deep sea fishermen patrol system for coastal intruder positioning/International Journal of Scientific Engineering and Technology (ISSN : 2277-1581)Volume 2 Issue 3, PP : 129-132 1 April 2013.
- [5] Google MAPS API <http://code.google.com/apis/maps>
- [6] P.Satheesh, Maritime Border Refuge System [MBR]/ National Conference on Emerging Trends in Computer, Communication & Instrumentation in Strengthening National Security.

AUTHOR PROFILE

Mr.R.Ranjith is pursuing B.E in the field of Electronics and Instrumentation Engineering in Sri Sairam Engineering College.His field of interest are control system,robotics.

Mr.M.Naveenkumar is doing B.E in the field of Electronics and Instrumentation Engineering in Sri Sairam Engineering College.